

## “DUAL LOCK” MOUNT

### PLEASE NOTE:

FAILURE TO FOLLOW THESE INSTRUCTIONS COMPLETELY WILL JEOPARDIZE THE PERFORMANCE OF YOUR NEW LOUVERS. PLEASE READ INSTRUCTIONS THOROUGHLY BEFORE BEGINING.

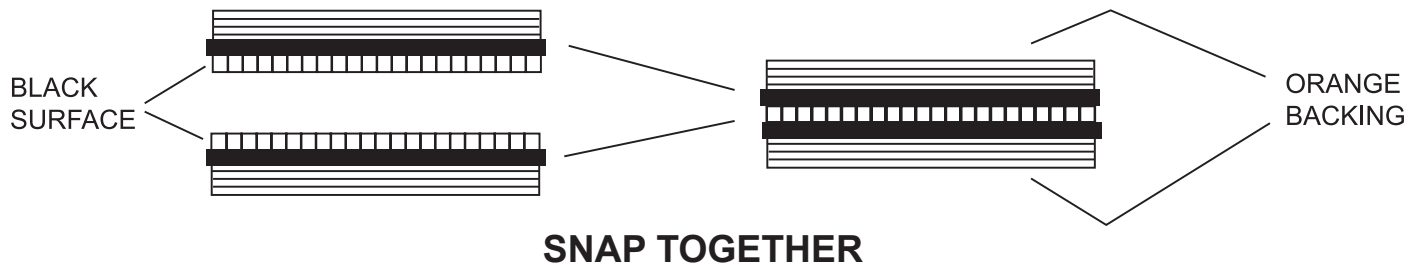

#### STEP 1

- Assemble the 16 “Dual Lock” mounting pads with the orange backing into 8 pairs as show. Simply snap the black interlocking surfaces together. This will provide you with 4 mounting pads for each louver.

#### STEP 2

- Wipe the back side of the louver mounting surfaces with denatured or rubbing alcohol to clean off any finger prints or other dirt and dust. Peel the orange backing from all eight mounting pad assemblies and apply to the louver in the approximate locations shown.

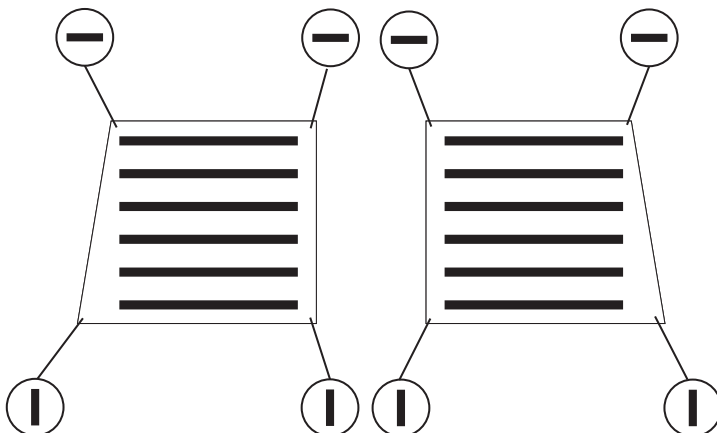

NOTE THE ORIENTATION OF THE PADS. TWO ARE HORIZONTAL AND TWO ARE VERTICAL.

BE SURE TO PRESS THE PADS FIRMLY IN PLACE.

### **STEP 3**

- Now apply the adhesive backed foam pad to edge of the louver on the back side between the mounting pads. Use a knife or razor blade to cut the tape as needed.

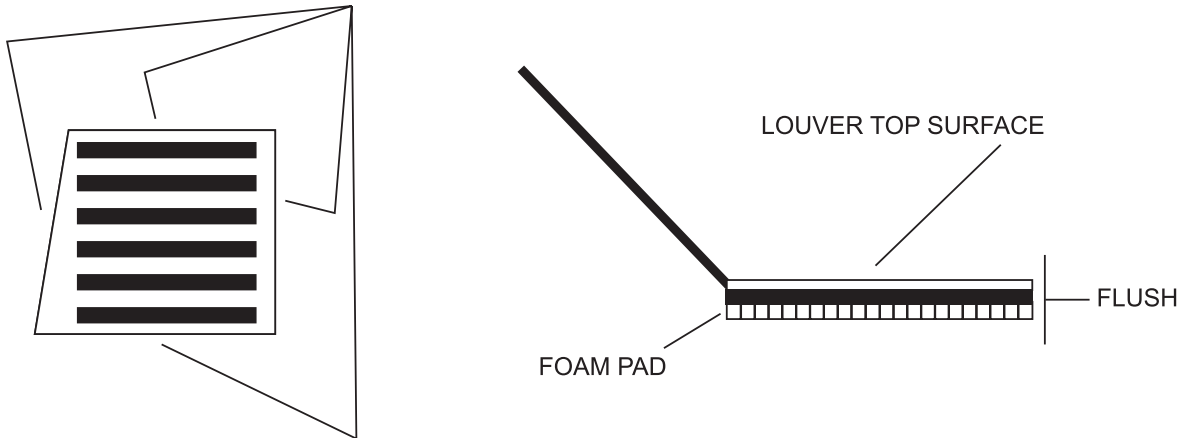

Apply foam pad to entire perimeter of the louver on the back side. Install the pad flush with the edge for best appearance.

### **STEP 4**

- Clean the glass as follows:
  1. Wash the windows with a mild detergent and water solution and dry with a lint-free cloth.
  2. Wipe the clean window with denatured or rubbing alcohol to ensure a completely clean window
  3. Installation should not be done unless the temperature of the glass is at least 80 degrees fahrenheit for proper performance of the mounting pad adhesive. Use a heat gun or hair dryer to achieve proper temperature if necessary.

### **STEP 5**

- Peel the orange backing from the mounting pads on each louver. Carefully locate each louver on the glass and press the mounting pad areas firmly to ensure full adhesive contact. The louvers should be left undisturbed for at least 48 hours after installation to allow the adhesive to properly cure. If the louvers need to be adjusted for location or for window cleaning, simply lift the louver in the area near the mounting pad and “unsnap” the louver from the glass. The “Dual Lock” fasteners are designed to be very strong. If any difficulty is experienced unsnapping the louver, simply use a small screw driver or dull knife blade to separate the halves of the mounting pad.

Your new louver is manufactured of the highest quality materials available and should give you years of trouble-free service. It may be washed and waxed just as you would the paint on your vehicle.

### **NOTE: FAILURE OF PROPER BONDING MAY BE ATTRIBUTED TO ONE OF FOUR ITEMS:**

- Poor surface preparation and/or application.
- Poor adhesive contact: exposed adhesive side of tape being touched or contaminated, insufficient pressure being applied.
- Adhesive being undercut due to prolonged exposure to high humidity, and not using silicone as recommended.
- Vehicle being driven too soon, tape not fully cured.